



DR Control Handles

Metered

- Model 3330-157.....DR Metered Control Handle w/rigid extension & 1/4 turn manual tip
- Model 3330-158.....DR Metered Control Handle flex 90 extension & 1/4 turn manual tip
- Model 3330-159.....DR Metered Control Handle w/flex-m extension & 1/4 turn manual tip
- Model 3330-160.....DR Metered Control Handle flex 90 extension & automatic tip
- Model 3330-161.....DR Metered Control Handle w/flex extension & automatic tip
- Model 3330-166.....DR Metered Control Handle - Bare (no extension)

Non-Metered

- Model 3320-022.....DR Control Handle w/rigid extension & 1/4 turn manual tip
- Model 3320-023.....DR Control Handle w/flex 90 extension & 1/4 turn manual tip
- Model 3320-024.....DR Control Handle w/flex-m extension & 1/4 turn manual tip
- Model 3320-025.....DR Control Handle w/flex 90 extension & automatic tip
- Model 3320-026.....DR Control Handle w/flex extension & automatic tip

Meter only

- Model 3120-091.....DR Inline meter



Thoroughly read and understand this manual before installing, operating or servicing this equipment.

Operation, Installation, Maintenance and Repair Guide

GENERAL SAFETY



! IMPORTANT

Read these safety warnings and instructions in this manual completely, before installation and start up of the control handle. It is the responsibility of the purchaser to retain this manual for reference. Failure to comply with the recommendations stated in this manual will damage the control handle and void factory warranty.



! WARNING

Airborne particles and loud noise hazards.

Wear ear and eye protection.

! CAUTION

- 1) Always read and follow the fluid manufacturers's recommendations regarding the use of protective eye wear, clothing, gloves, and other personal equipment.
- 2) Never alter or modify any parts of this product; doing so may cause damage and/or personal injury.

! CAUTION

Maximum Fluid Pressure 1450 PSI (100 bar). Under no circumstances should the control handle be aimed at any person or your own body at anytime. Personal injury may result.



! WARNING

DANGER: Not for use with fluids that have a flash point below 100°F (38°C, examples: gasoline, alcohol). Sparking could result in an explosion which could result in death.

TABLE OF CONTENTS

Cover.....	1
General Safety.....	2
Product Description.....	2
Technical Specifications.....	3
Operation.....	3 - 4
Configuration.....	4
Calibration.....	4 - 5
Maintenance.....	6 - 9
Troubleshooting.....	8
Parts List.....	9 & 10
Repair Kits.....	11
Warranty Information.....	Back Cover



! WARNING

Always use the following Pressure Relief Procedure whenever shutting off, cleaning, or in any way checking or servicing the control handle:

- 1) Disconnect compressed air line or turn off power supply at the fluid pump.
- 2) Point the control handle outlet into a waste container and open trigger to relieve pressure.
- 3) Open any bleed-type supply air valves and fluid drain valves in the system.
- 4) Leave the drain valves open until you are ready to re-pressurize the system.

PRODUCT DESCRIPTION

The DR Electronic Control Handle is designed specifically to dispense motor oils, automatic transmission fluid, antifreeze (Glycol) and antifreeze/water solution. Perfect balance, lightweight, ruggedness, and comfortable grip make it the best choice for overhead reel systems. When not in use for 30 seconds, the meter enters "sleep mode", which prolongs battery life. When in sleep mode, the meter is turned on by a simple press of the ON/RESET button or if the meter detects fluid flow. The trigger allows for progressive opening of the valve for better control of oil delivery and incorporates a trigger lock to prevent accidental opening. The valve can be locked in the open position by means of the trigger lock button.



! WARNING

Do not place your hand or fingers over the dispensing nozzle and/or aim the nozzle at a person at any time. Personal injury may result.

The electronic register module can be programmed to dispense in pints, quarts, liters, or gallons and will totalize in liters or gallons. A calibration factor and unit of measure are programmed during factory test. A 5-digit liquid crystal display, accurate to the third decimal place, shows the exact amount of fluid dispensed.

TECHNICAL SPECIFICATIONS

Accuracy (after field calibration).....	+/- 0.5%
Flow range.....	0.25 - 8 Gal/min.
Max working pressure (handle w/meter).....	1450psi (100bar)
Max working pressure (handle only).....	1450psi (100bar)
Weight (meter only).....	1.2 lbs
Weight (handle only).....	1.1 lbs
Weight (handle w/meter).....	2.3 lbs
Inlet.....	1/2" NPT compatible
Outlet.....	1/2" NPT compatible
Operating Temp. Range.....	14°F - 140°F
Fluid compatibility.....	Oils (up to SAE 140), ATF, Antifreeze (Glycol), Antifreeze/ water solution
Wetted Parts.....	Aluminium, Acetal, NBR, Zinc Plated Steel, Stainless Steel

DISPLAY FUNCTIONS

ON/RESET BUTTON

Press once to switch on the meter. Press and hold for 1 second to reset the batch total or the "Trip" to zero. This button is also used when programming the unit of measure and during calibration.

SELECT BUTTON

Press once to toggle through batch, trip, and cumulative totals. This button is also used when programming the unit of measure and during calibration.

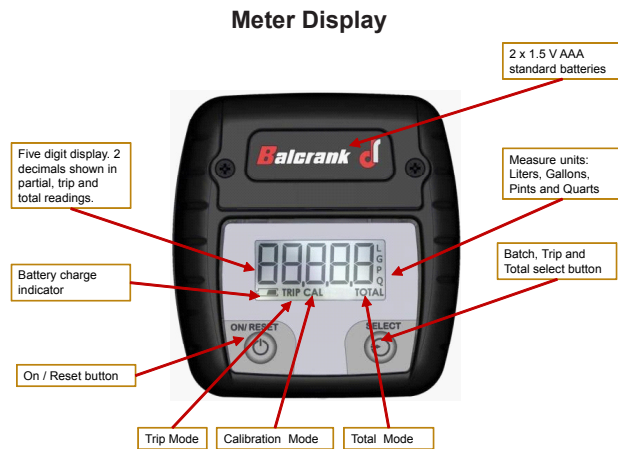

OPERATION

Press the ON/RESET button to turn on the meter, The meter performs a check on the display by showing all the segments briefly (Fig. 1). If needed, reset the batch total to zero by pressing the ON/RESET button for 1 second (Fig. 2). To dispense fluid, press the locking button (Fig. 3) and squeeze the trigger handle. The locking button can be pressed again after fully squeezing the trigger to lock the valve open.

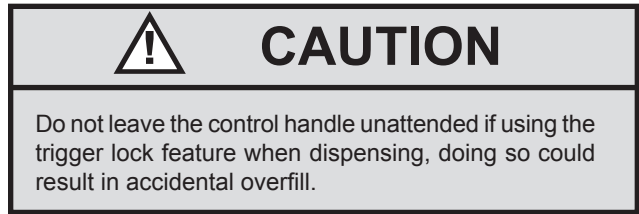

To release the trigger lock, pull in on the trigger, this will release the locking button and allow the valve to close.

Fig. 1

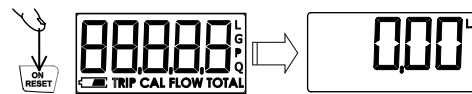

Fig. 2

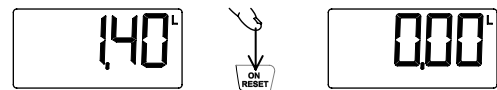
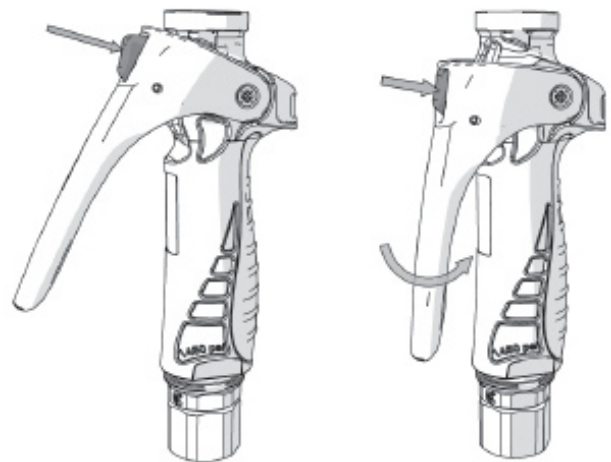

Fig. 3



TOTALIZERS

The BATCH total is a resettable total that displays the current running total while dispensing fluid. To reset the BATCH total, press and hold the ON/RESET button for 1 second (Fig. 2).

The TRIP is a resettable total that can be used to track the quantity that has been dispensed over a given period which can then be reset to zero when desired. The TRIP totalizer is reached by pressing the SELECT button (Fig. 4). To reset the TRIP totalizer, press and hold the ON/RESET button for 1 second.

Fig. 4

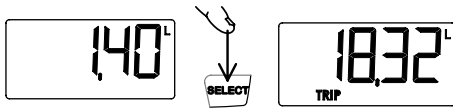

The TOTAL is a non-resettable total that keeps a running total for the life of the meter (Fig. 5).

Fig. 5

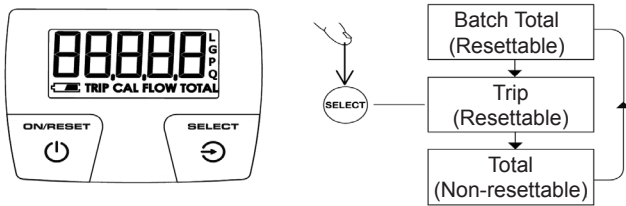
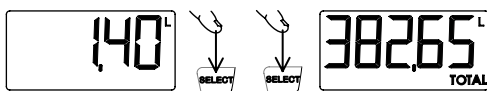

CONFIGURATION - Unit of Measure

The meter has four possible combinations of units of measure that can be set based on the table below.

Batch Total	TRIP Register	Total Register
Liters (L)	Liters (L)	Liters (L)
Gallons (Gal)	Gallons (Gal)	Gallons (Gal)
Quarts (Qt)	Quarts (Qt)	Gallons (Gal)
Pints (Pt)	Pints (Pt)	Gallons (Gal)

To change between these combinations, the meter must be in batch mode. With the meter displaying the batch total (Fig. 6) press and hold the ON/RESET and SELECT buttons simultaneously for 1 second (Fig. 7). The word "Unit" will appear in the display. You can then change the unit of measure by pressing the SELECT button until the desired unit of measure is displayed (Fig. 8). To save the new unit of measure, press the ON/RESET button (Fig. 9).

UNITS OF MEASURE

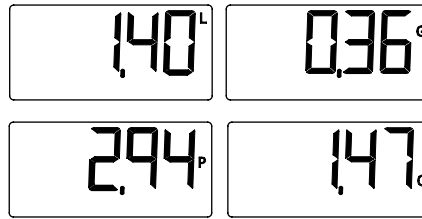

Fig. 6



Fig. 7

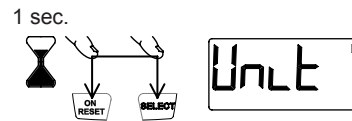
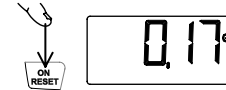

Fig. 8



Fig. 9



CONFIGURATION - Calibration

The meter is calibrated at the factory and does not normally require calibration for the fluids generally used in workshops. If using fluids with high or low viscosity, as well as if working with high flows or very low flows, calibration may be required.

Calibration may also be required after having used the meter for a long time, especially if working with fluids with that leave behind residues.

Verify the precision of the meter prior to use and proceed with calibration if required.

In order to perform the calibration process correctly the following rules must be adhered to:

1. The calibration can be performed for any volume, however it is recommended that a minimum of 1 unit (Quart, Gallon, Pint, Liter) and a maximum 25 units can be used.
2. The container used must be calibrated and be completely empty (prior use of the container can easily leave behind 0.1 quarts even if it appears to be empty). Put the container upside down for a while, or clean it before starting the calibration process.

3. When the fluid is being released you must wait until all the air contained in it is eliminated. This can take some time. If precision scales are used the accumulation of air has no effect.

CALIBRATION PROCEDURE

The calibration process is semi-automatic. To start the process, the meter must be in batch mode (Fig. 10) and is accessed by simultaneously pressing the buttons ON/RESET and SELECT for 3 seconds (Fig. 11). After releasing the buttons the current calibration factor is shown on the meter (Fig. 12).

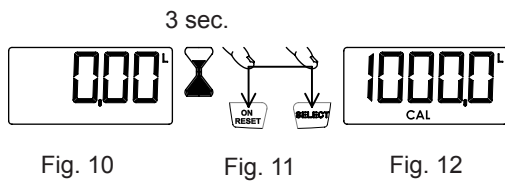

If the screen does not show the correct unit of measure (Fig. 12) press the SELECT button (Fig. 13) successively until displaying the required unit (Fig. 14). Press ON/RESET (Fig. 15) to start the calibration process (Fig. 16).

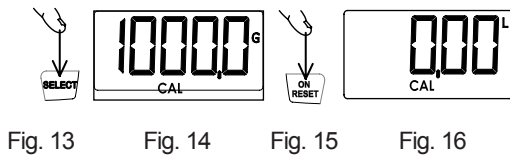

Begin dispensing the desired volume into the container. Remember that you must release at least 1 unit (Quart, Gallon, Pint, or Liter) to perform a good calibration. In the example shown the actual volume that has been dispensed is 2 liters according to the reading on the calibrated container (Fig. 17) and that the meter recorded 2.1 liters (Fig. 18).

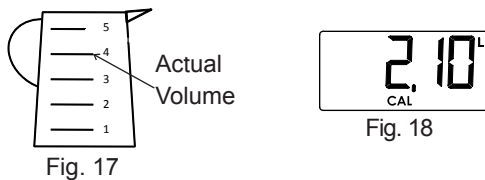

To adjust the meter to the actual quantity dispensed (measured in the calibrated container or scales), press the ON/RESET button for 1 second (Fig. 19). The digits start to flash (Fig. 20) indicating that the value shown can be modified. Each press of the ON/RESET button increases the value by 0.1 unit and each press of the SELECT button (Fig. 21) reduces this value by 0.1 unit (Fig. 22).

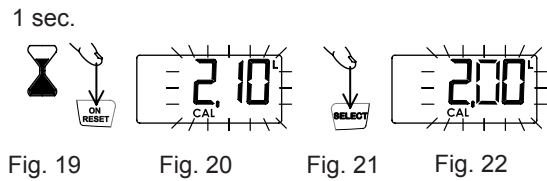

Once the meter has been adjusted to reflect the actual quantity that was dispensed (Fig. 22) press the ON/RESET button for 1 second (Fig. 23). The meter shows the new stored calibration factor (Fig. 24) and then exits the calibration process. The screen shows the batch total with the unit that was set during the calibration process (Fig. 25).

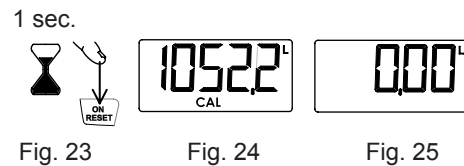

If, during any phase of the calibration process, you wish to exit without saving the changes made you must press the SELECT button for 1 second. Likewise, if 30 seconds of inactivity elapses during the process, the meter switches off automatically and exits the calibration process without storing the data.

NOTE

For proper calibration it is important to:

- completely eliminate air from the system
- use an accurate sample container
- during calibration, ensure dispensing is done at a constant flow rate equivalent to normal dispensing until the container reaches the desired quantity. You may start and stop the flow but do not "trickle" flow
- after dispensing wait a short period to ensure any air bubbles have dissipated

MAINTENANCE

The meter is designed to be virtually maintenance free. The only maintenance required is periodic battery replacement.

The meter comes complete with two 1.5 V size AAA alkaline batteries. The function of the low-battery alarm icon is shown below.



BATTERIES OK (NO ICON)



BATTERIES HALF CHARGED
(HALF ICON)



BATTERIES DEAD (EMPTY ICON)
REPLACE THE BATTERIES

1. Remove the two #2 phillips screws in the battery cover as shown (Fig 26).
2. Remove the old batteries.
3. Install the new batteries (observe polarity).
4. Re-install the battery cover and tighten the screws.

When new batteries are installed, the display will briefly show the software version (similar to the below).

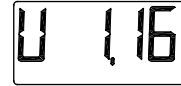

	WARNING
Always use the following Pressure Relief Procedure whenever shutting off, cleaning, or in any way checking or servicing the control handle:	
<ol style="list-style-type: none">1) Disconnect compressed air line or turn off power supply at the fluid pump.2) Point the control handle outlet into a waste container and open trigger to relieve pressure.3) Open any bleed-type supply air valves and fluid drain valves in the system.4) Leave the drain valves open until you are ready to re-pressurize the system.	

REPLACING THE BATTERIES

	NOTE
Observe the polarity on the batteries when installing	

The location of the batteries is shown below

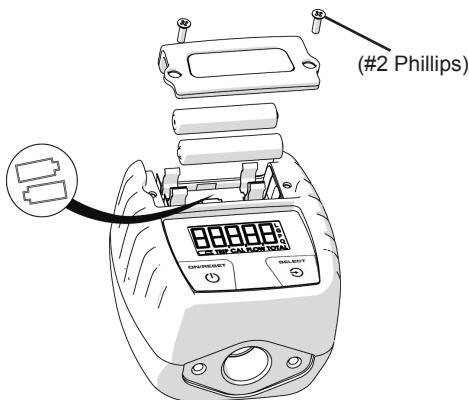

Fig. 26

CLEANING THE FLUID CHAMBER

Refer to the steps below and Figure 27 (on page 9) for cleaning the fluid chamber.

1. Remove the four #2 phillips screws from the rear casing (4), then remove the back cover
2. Lift off the front casing/display assembly (3)
3. Remove the eight 2.5mm allen screws of the metering chamber cover, then remove the cover (1)
4. Make note of the position/orientation of the oval gears (2), then remove the oval gears
5. Clean the chamber and the gears carefully using a soft brush
6. Replace the oval gears (ensure they are re-installed in the position/orientation in which they were removed).
7. Replace the metering chamber cover and tighten the allen screws
6. Replace the top cover/display assembly, the back cover and install the phillips screws.

REPLACING THE VALVE ASSEMBLY

1. Loosen and remove the swivel (1), then remove the spring (2), the valve (3) and the rod (4).
2. Reassemble in reverse order.

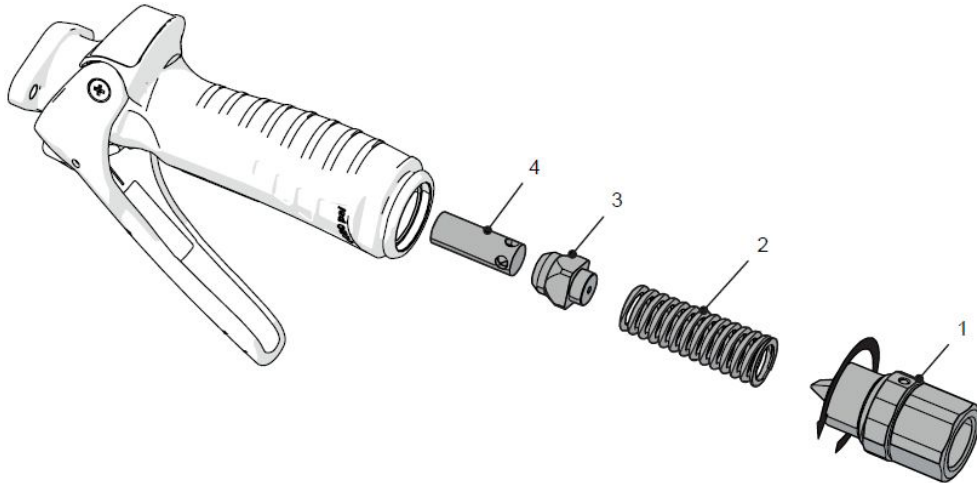

REPLACING THE CAM O-RINGS

1. Disassemble the valve as described above.
2. Remove the #2 phillips screws from the cam (4) and remove the trigger (5).
3. To avoid damaging the o-rings, push the cam (6) out on one side until only the o-ring of that side (7) is exposed.
4. Remove the o-ring (7) and then fully remove the cam with the other o-ring (8) on the opposite side.
5. To re-assemble, proceed the other way around taking care with the installation of the o-rings on the cam.
6. To avoid damage to the o-rings in the cam assembly, install a single o-ring (8) on cam (6) and place the end of the cam without the o-ring into the gun.
7. Slide the in cam until the end without o-ring appears on the other side of the gun, taking care that only the groove of the o-ring is exposed. Install the o-ring (7) and push the cam into position.
8. Re-install trigger and screws.
9. Re-install the valve assembly.

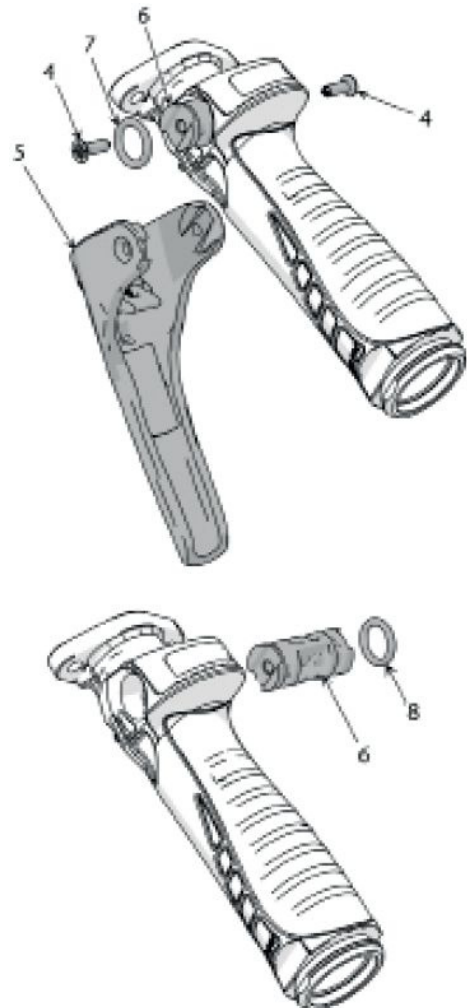

REPLACING THE FILTER SCREEN

1. Remove the o-ring (3) fixing the filter screen (4) and then remove the filter screen.
2. Inspect the filter and clean or replace it as necessary.
3. Replace the filter screen with the o-ring and the re-connect the hose and install swivel cover (optional)

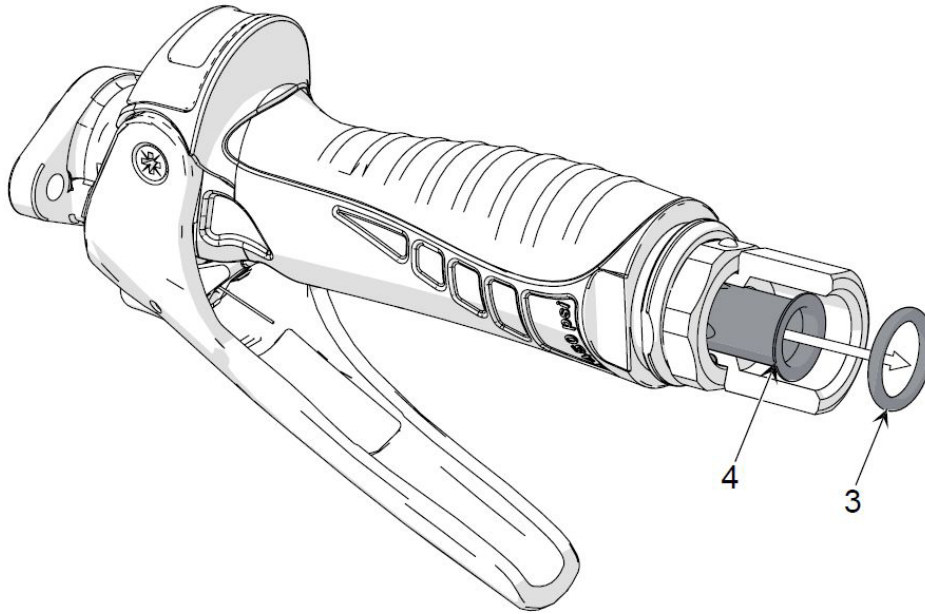

TROUBLESHOOTING

Symptom	Possible Cause	Remedy
Blurred or unclear reading.	Batteries dead.	Replace the batteries.
The meter does not switch on.	Batteries dead.	Replace the batteries.
The meter is inaccurate.	Erroneous calibration factor.	Calibrate the meter.
	A fluid with very high or very low viscosity is being used.	Calibrate the meter.
	Very high or low fluid temperature.	Calibrate the meter.
	The meter is working outside its field of application (see technical specifications).	Restore the working conditions (flow, viscosity, temperature...) to those required by the meter.
Reduced flow.	Dirt in the measuring chamber.	Clean the measuring chamber.
	Strainer clogged	Clean or replace the strainer
The meter does not count.	Faulty reed sensor.	Inform technical support.
Valve leaks	Valve seal worn or damaged	Dissassemble the valve for inspection. If not damaged, clean an re-seat valve. If damaged, replace the valve.
	Foreign material on valve seat	
Leak at trigger cam	O-ring worn or damaged	Replace the O-ring
Leak at swivel	Swivel is loose	Tighten swivel assembly
	Swivel O-ring worn or damaged	Replace the O-ring

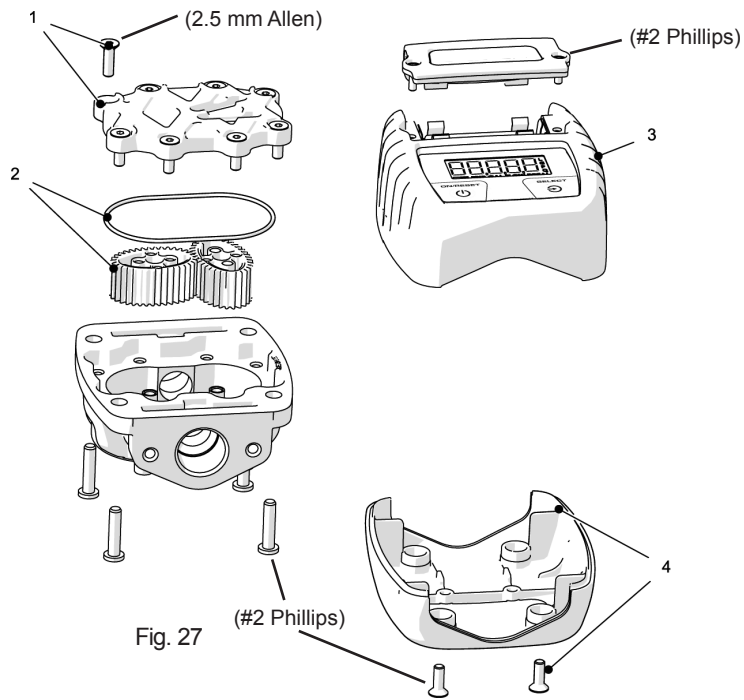

METER DIMENSIONS

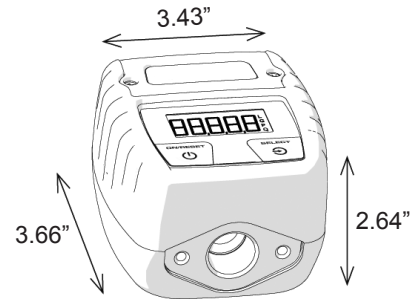

PARTS LIST (Meter)

Item	Description	Qty
1	Counter-sunk screw	8
	Metering chamber cover	1
2	O-Ring	1
	Oval gear	2
	Magnet	2

Item	Description	Qty
3	Electronic card	1
	Front Casing	1
	Screw w/plastic thread PCB	4
	Screw w/plastic thread casing	4
4	Rear casing	1
	Self-tapping screw	4

**CONTROL HANDLE
DIMENSIONS**

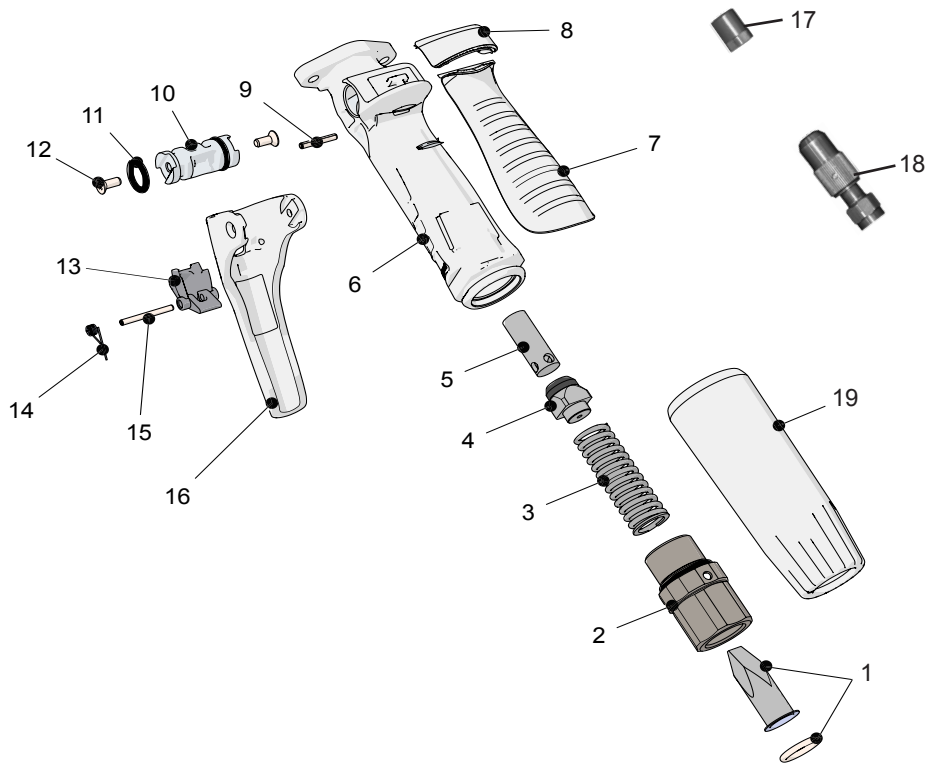

PARTS LIST (Control Handle)

Item	Description	Qty.
1	O-ring Strainer	1
2	Swivel	1
3	Spring	1
4	Valve	1
5	Rod	1
6	Body	1
7	Grip	1
8	Cover	1
9	Pin	1

Item	Description	Qty.
10	Cam	1
11	O-ring	2
12	Self tapping screw	2
13	Lock/unlock button	1
14	Trigger spring	
15	Pin	1
16	Trigger	1
17	Automatic non-drip tip	1
18	1/4 Turn Manual non-drip tip	1
19	Swivel cover	1

REPAIR KITS

Description	Part Number	Included Items
Inlet swivel kit	833306	1 & 2 (from page 10)
Trigger kit	833307	9 & 13 - 16 (from page 10)
Valve kit	833308	3 - 5 (from page 10)
Cam kit	833309	10 - 12 (from page 10)
Swivel Cover	833354	19 (from page 10)
Gears kit	833310	2 (from page 9)
Circuit board kit	833311	3 (from page 9)

MODELS

Model	Extension - Tip Type	Extension Part No.	Nozzle/Tip Part No.
3330-157	Rigid - 1/4 turn manual	3332-091	3332-096
3330-158	Flex 90 - 1/4 turn manual	3332-092	
3330-159	Flex-m - 1/4 turn manual	3332-093	
3330-160	Flex 90 - automatic	3332-094	3332-097
3330-161	Flex - automatic	3332-095	
3320-022	Rigid - 1/4 turn manual	3332-091	3332-096
3320-023	Flex 90 - 1/4 turn manual	3332-092	
3320-024	Flex-m - 1/4 turn manual	3332-093	
3320-025	Flex 90 - automatic	3332-094	3332-097
3320-026	Flex - automatic	3332-095	

**For Warranty Information Visit
www.balcrank.com**

Balcrank® Corporation
115 Reems Creek Road
Weaverville, NC 28787
800-747-5300
800-763-0840 Fax
www.balcrank.com

SERVICE BULLETIN SB3095
Rev. B 10/13

Revision Log:

Rev. A - Release
Rev. B - Corrected meter max working pressure and added
maintenance instructions for valve, inlet filter and
cam o-rings